







As you read these instructions, you will see WARNINGS, CAUTIONS, NOTICES and NOTES. Each message has a specific purpose. WARNINGS are safety messages that indicate a potentially hazardous situation, which, if not avoided could result in serious injury or death. CAUTIONS are safety messages that indicate a potentially hazardous situation which, if not avoided, may result in minor or moderate injury. A CAUTION may also be used to alert against unsafe practice. CAUTIONS and WARNINGS identify the hazard, indicate how to avoid hazard, and advise of the probable consequence of not avoiding the hazard. NOTICES are messages to avoid property damage. NOTES are additional information to help you complete a procedure. **PLEASE WORK SAFELY!**

 <b>WARNING</b>		
		
<p><b>MOVING PARTS ENTANGLEMENT HAZARD</b> Failure to observe these instructions could lead to severe injury or death.</p> <p>To avoid injury to hands or fingers.</p> <ul style="list-style-type: none"> <li>• <b>Always</b> keep hands clear of wire rope, hook loop, hook and fairlead opening during installation, operation, and when spooling in or out.</li> <li>• <b>Always</b> use extreme caution when handling hook and wire rope during spooling operations.</li> <li>• <b>Always</b> use supplied hook strap whenever spooling wire rope in or out, during installation or operation to avoid injury to hands or fingers.</li> </ul>		

 <b>WARNING</b>	
	
<p><b>CHEMICAL AND FIRE HAZARD</b> Failure to observe these instructions could lead to severe injury or death.</p> <ul style="list-style-type: none"> <li>• <b>Always</b> remove jewelry and wear eye protection.</li> <li>• <b>Never</b> lean over battery while making connections.</li> <li>• <b>Always</b> verify area when drilling is clear of fuel lines, fuel tank, brake lines, electrical wires, etc</li> <li>• <b>Never</b> route electrical cables:             <ul style="list-style-type: none"> <li>- Across any sharp edges.</li> <li>- Through or near moving parts.</li> <li>- Near parts that become hot.</li> </ul> </li> <li>• <b>Always</b> insulate and protect all exposed wiring and electrical terminals.</li> <li>• <b>Always</b> install terminal boots as directed in installation instructions.</li> </ul>	

 <b>WARNING</b>	
	
<p><b>FALLING OR CRUSHING HAZARD</b> Failure to observe these instructions could lead to severe injury or death.</p> <ul style="list-style-type: none"> <li>• <b>Never</b> use as an overhead hoist, or to suspend a load.</li> <li>• <b>Never</b> use to lift or move persons.</li> </ul>	

 **CAUTION**

**MOVING PARTS ENTANGLEMENT HAZARD**  
Failure to observe these instructions could lead to minor or moderate injury.

**General Safety:**

- **Always** Know Your Winch: Take time to fully read and understand the included Installation and Operations guide, and Basic Guide to Winching Techniques, in order to understand your winch and the winching operation.
- **Never** operate this winch if you are under 16 years of age.
- **Never** operate this winch when under the influence of drugs, alcohol or medication.
- **Never** exceed winch or wire rope rated capacity. Double line using a snatch block to reduce winch load.

**Installation Safety:**

- **Always** choose a mounting location that is sufficiently strong to withstand the maximum pulling capacity of your winch.
- **Always** use factory approved switches, remote controls, accessories and installation components.
- **Always** use grade 5 or better hardware, never weld bolts and never use longer bolts than those supplied from factory.
- **Always** complete winch mounting and attachment of hook to hook loop before wiring winch during installation.
- **Always** position fairlead with WARNING label on top.
- **Always** spool the wire rope onto the drum as indicated by the drum rotation label on the winch. Required for automatic brake to work (if winch is so equipped) and for correct installation orientation.
- **Always** prestretch wire rope and respool under load before use. Tightly wound wire rope reduces chances of "binding", which is wire rope working it's way down into a loosely wound wire rope layer, and catching or damaging itself.

 **CAUTION**

**MOVING PARTS ENTANGLEMENT HAZARD**  
Failure to observe these instructions could lead to minor or moderate injury.

**Winching Safety:**

- **Always** inspect winch installation, wire rope and hook condition before operating winch. Frayed, kinked or damaged wire rope must be replaced immediately. Loose or damaged winch installation must be corrected immediately. Immediately replace a hook that is damaged, bent or twisted.
- **Never** leave remote control plugged into winch while free spooling, rigging, or sitting idle.
- **Never** hook wire rope back onto itself. This damages the wire rope. Always use a choker chain, wire choker rope or tree trunk protector on the anchor.
- **Always** prior to winching, remove any element that may interfere with safe winch operation.
- **Always** take your time when rigging for a winch pull.
- **Always** be certain the anchor you select will withstand the load, and the strap or chain will not slip.
- **Never** engage or disengage clutch if winch is under load, wire rope is in tension or wire rope drum is moving.
- **Always** unspool as much wire rope as possible when rigging. Double line or pick distant anchor point.
- **Never** winch with less than 5 wraps of wire rope around the drum, the wire rope could come loose from the drum.
- **Always** stand clear of wire rope and load during operation.
- **Never** touch wire rope or hook while in tension or under load.
- **Never** touch wire rope or hook while someone else is at the control switch or during winching operation.
- **Never** touch wire rope or hook while remote control is plugged into winch.
- **Always** stand clear of wire rope and load and keep others away while winching.

 **CAUTION**

**MOVING PARTS ENTANGLEMENT HAZARD**  
Failure to observe these instructions could lead to minor or moderate injury.

**Winching Safety:**

- **Always** require operator and bystanders to be aware of stability during winching of vehicle and/or load.
- **Always** keep remote control lead clear of the drum, wire rope and rigging. Inspect for cracks, pinches, frayed wires or loose connections. Replace if damaged.
- **Always** pass remote control through a window to avoid pinching lead in door, when using remote inside a vehicle.

 **CAUTION**

**CUT AND BURN HAZARD**  
Failure to observe these instructions could lead to minor or moderate injury.

**To avoid injury to hands or fingers:**

- **Always** wear heavy leather gloves when handling a wire rope.
- **Never** let wire rope slip through your hands.

**To avoid injury to hands or fingers:**

- **Always** be aware of possible hot surface at winch motor, drum or wire rope during or after winch use.

 **CAUTION**

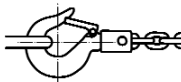
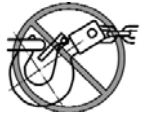
**MOVING PARTS ENTANGLEMENT HAZARD**  
Failure to observe these instructions could lead to minor or moderate injury.

- **Never** apply load to hook tip or latch. Apply load only to the center of hook.
- **Never** use a hook whose throat opening has increased, or whose tip is bent or twisted.

**NOTICE**

**AVOID WINCH AND EQUIPMENT DAMAGE**

- **Always** avoid continuous side pulls which can pile up wire rope at one end of the drum. This can damage your wire rope or winch.
- **Always** ensure the clutch is fully engaged or disengaged.
- **Never** use winch to tow other vehicles. Shock loads can momentarily exceed capacity of wire rope and winch.
- **Always** use care to not damage your frame when anchoring your vehicle during a winching operation.
- **Never** "jog" wire rope under load. Shock loads can momentarily exceed capacity of wire rope and winch.
- **Never** use winch to secure a load during transport.
- **Never** submerge winch in water.
- **Always** store the remote control in a protected, clean, dry area.

## Winch Mounting

- Choose a mounting location that is sufficiently strong enough to withstand the loads you intend to winch.
- Find the diagrams of your winch on the following pages. Refer to them for proper orientation. Only the mounting orientations shown are possible for safe winching operation. All others are improper and inappropriate.
- The wire rope must always spool onto the drum as indicated by the drum rotation decal.
- The use of recommended bolt and lock washer combinations torqued to recommended levels will prevent vibration during operation. Find the diagrams of your winch on the following pages. Refer to them for proper torque levels.

## Electrical Connections

- Make sure to use the insulating boots on the exposed connections to prevent electrical shorting. Route battery connection cables in areas which will not cause them to chafe or cut through the insulation causing a potential short circuit.
  - Upon completion of installation, check winch for proper operation.
- Refer to the diagrams for your winch on the following pages.

## WARNING



To avoid serious injury or death from electrical fire:

- Never route electrical cables:
  - Across any sharp edges.
  - Through or near moving parts.
  - Near parts that become hot.
- Always insulate and protect all exposed wiring and electrical terminals.
- Always install terminal boots as directed in installation instructions.



### Mounting location:

- (1) Smooth and flat, thickness = 1/4" (6.4 mm)
- (2) 3/8" (9.525 mm) lockwasher X 4
- (3) 3/8-16 X 1 1/4" long, grade 5 bolt X 4 torque 30-35 ft. lbs. (41-47Nm)

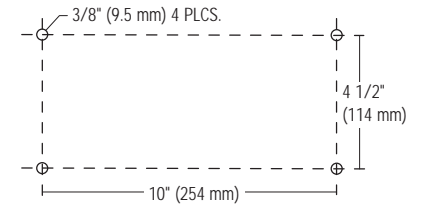

### Mounting bolt pattern:

10.0" x 4.5", 254mm x 114.3mm

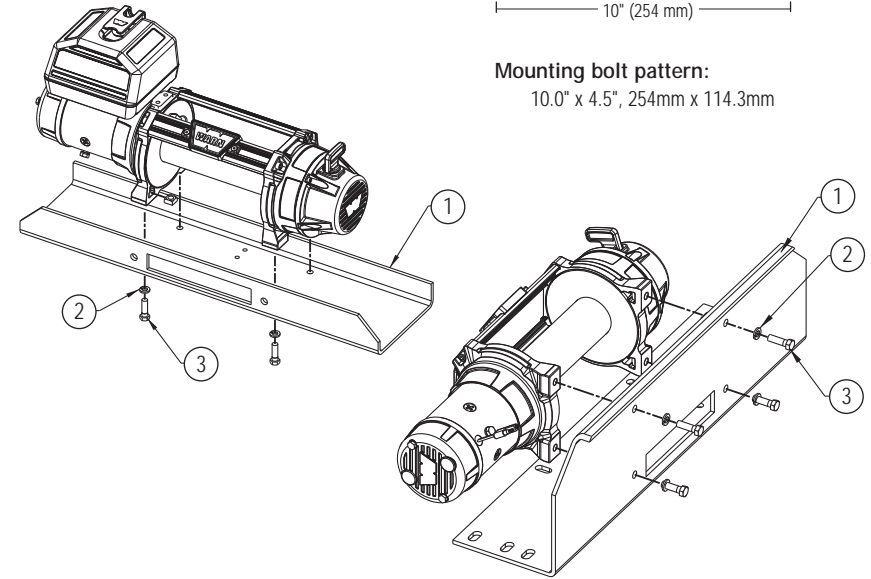

## ELECTRICAL CONNECTIONS

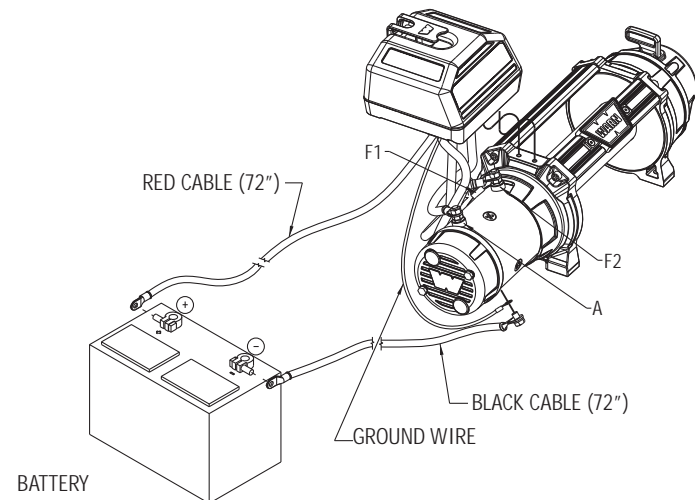

## Cooling Fan Mounting Instructions

- The fan must be correctly installed to provide the best performance. The fan should be mounted in a location that is as clean, dry, and cool as possible. The mounting location must also provide clearance for the fan's control cable as well as the outlet hose. When mounting the fan, insure that the inlet is unobstructed and higher than the winch. Also insure that the winch exhaust outlet is not near the fan inlet.
- Best locations for the fan will vary depending on the vehicle. Typical location include: near air intake box and inner fender inside engine compartment. Avoid mounting fan near exhaust manifold, turbocharger, or radiator. Maximum operating temperature is 175°F (80°C). Avoid sharp edges when routing fan control cable and hose.
- If your vehicle is used in extremely dusty conditions you can choose to equip the winch cooling fan with a high performance filter. Filter part number RC-0790 available from K&N Filters is recommended for this application. The filter can be installed directly to the fan inlet.

## WARNING

To avoid serious injury or death from electrical fire:



- Never route electrical cables:
  - Across any sharp edges.
  - Through or near moving parts.
  - Near parts that become hot.
- Always insulate and protect all exposed wiring and electrical terminals.
- Always verify area when drilling is clear of fuel lines, fuel tank, brake lines, electrical wires, etc



### Mounting steps:

1. Determine the fan mounting location.
2. Mount fan on a flat surface, mark and drill mounting holes.
3. Loosely attach the fan using WARN supplied 1/4-inch bolts, lock nuts, and washers or sheet metal screws.
4. Tighten fasteners.
5. Attach hose to fan outlet.
6. Route fan outlet hose to winch and tie down with tie wraps. Cut off excess hose.
7. Thread plastic fittings into winch motor end cap. Tighten and align fitting with hose.
8. Connect the fan outlet hose to the plastic fitting positioned above the "W" on the motor end cap.
9. Route fan control cable along fan outlet tubing and attach with tie wraps.
10. Connect fan control cable to plug behind and below winch control pack.
11. Connect the remaining hose to the plastic fitting positioned below the "W" on the motor end cap.
12. Route winch exhaust hose and tie down with tie wraps. Cut off excess hose.

## CAUTION

**ALWAYS KNOW YOUR WINCH:** Take time to fully read and understand the included Operator's Guide, and Basic Guide to Winching Techniques, in order to understand your winch and the winching operation.

### REMOTE CONTROL SWITCH

Do not leave the remote plugged into the winch when not in use. Leaving the remote plugged in, may result in a dangerous condition and/or battery drain.

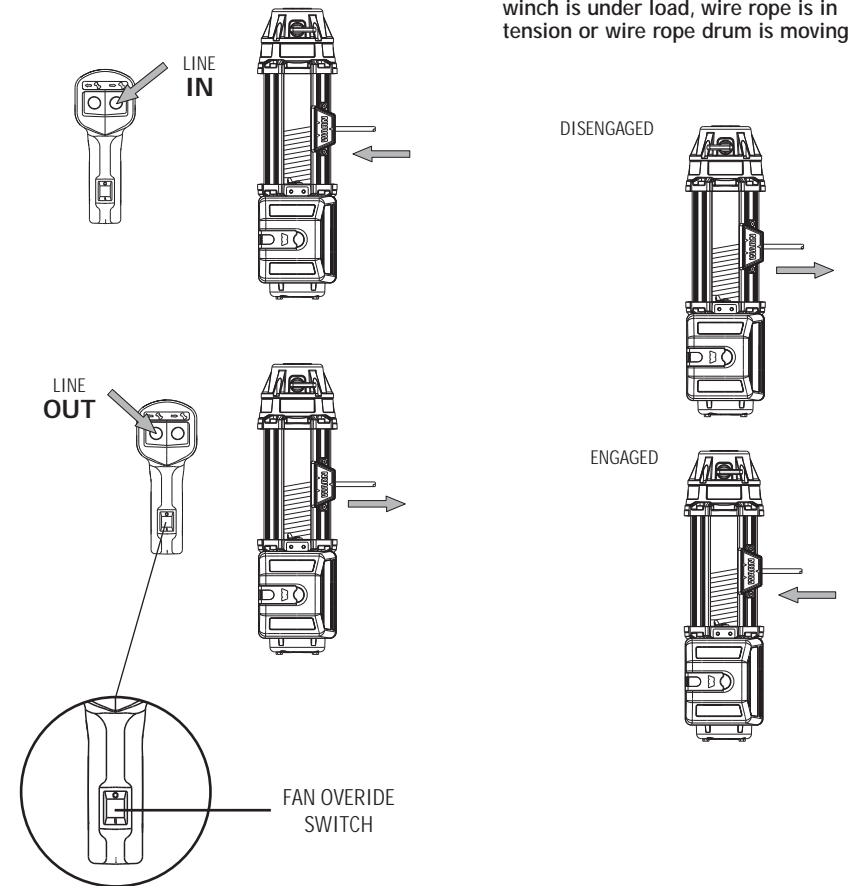

### CLUTCH OPERATION

When the clutch is engaged the gear train is coupled to the wire rope drum and power may be transferred from the winch motor. When the clutch is in free spool the gear train and wire rope drum are uncoupled allowing the drum to rotate freely. The clutch knob, located on the winch housing opposite the motor, controls the clutch position. To prevent damage, always fully engage or fully disengage the clutch knob.

## CAUTION

To avoid minor or moderate injury:

- Never engage or disengage clutch if winch is under load, wire rope is in tension or wire rope drum is moving.

## STRETCHING WIRE ROPE

**WARNING**

To prevent severe injury or death:



- Always keep hands clear of wire rope, hook loop, hook and fairlead opening during installation, operation, and when spooling in or out.
- Always use extreme caution when handling hook and wire rope during spooling operations.
- Always use supplied hook strap whenever spooling wire rope in or out, during installation or operation to avoid injury to hands or fingers.

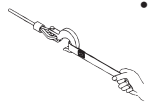

The life of a wire rope is directly related to the use and care it receives. During its first use, a new wire rope must be spooled onto its drum under a load of at least 1000 lbs. (454 kgs). Use the following instructions to properly stretch the wire rope onto the winch drum.

- 1) Choose a **FLAT AND LEVEL** location that is large enough to run out the entire length of wire rope.
- 2) Turn the clutch lever on the winch to the "Free Spool" position. Spool out the wire rope to the last 5 wraps on the drum. Once the wire rope is spooled out, turn the clutch lever on the winch to the "Engaged" position.
- 3) Attach the hook end of the rope to a suitable anchor point and back the vehicle away from the anchor point until there is very little slack in the wire rope. Before getting out of the vehicle, set the parking brake, place the vehicle in gear or park and turn the vehicle off.

4) Connect the remote control to the winch. Standing approximately 6 ft away from the winch, power in the winch until all of the slack is wound onto the winch drum. Disconnect the remote control from the winch. Hold tension on the wire rope with one hand: carefully push the wire rope to the side of the drum the wire rope is attached to so there are no gaps between each coil on the drum. Be sure to check that the wire rope is winding off of the bottom of the drum, not the top, or the automatic load holding brake will not function properly. (If the wire rope is winding off the top you have powered the winch "out" instead of "in" on the remote control).

5) The following steps should be done using two people for proper safety. If you attempt to tension your wire rope alone be sure to always engage the parking brake, place the transmission in gear and turn the vehicle off every time you exit the vehicle to inspect the winch wire rope. Never exit the vehicle with a load on the winch wire rope. Tensioning the wire rope is critical to ensure a long product life. Tensioning the wire rope will prevent outer layers of wire rope from pinching and deforming the inner layers.

6) Use care to evenly wrap each layer to prevent damage to the rope.

7) Pass the remote control through the driver's window for the driver of the vehicle to operate. Instruct your assistant to stand to the side of the vehicle and away from the winch wire rope. Your assistant should signal you if the wire rope is winding correctly by watching it move across the fairlead as the wire rope is powered in. Start the vehicle and place the transmission in neutral. Release the parking brake while applying moderate brake pedal pressure. Press power in on the remote control switch. After winching in for approximately 6 ft, stop winching. Slowly let up off of the brake pedal and then apply the parking brake. This will ensure that there is no load on the winch rope. Then place the transmission in park or gear and turn the vehicle off. Exit the vehicle and inspect the winch to make sure that the wire rope is being evenly wound onto the winch drum and not sinking into the lower layer. If the wire rope is sinking, power the wire rope out and repeat this step from the beginning with more brake pedal pressure.

8) When you are convinced the wire rope is winding onto the winch drum properly, repeat step 6 until the vehicle is within 6 ft of the winch anchor. Once within 6 ft, slowly let up off of the brake pedal and then apply the parking brake. This will ensure that there is no load on the winch wire rope. Then place the transmission in park or in gear and turn the vehicle off. Exit the vehicle. Disconnect the hook from the anchor. While holding onto the supplied hook strap, hold tension on the winch rope and slowly power in the winch by "pulsing" the power in on the remote control until the hook is within 3 ft of the fairlead. Stop winching in and attach the hook to a suitable anchor point on the vehicle. **DO NOT POWER THE HOOK INTO THE FAIRLEAD.** This could cause damage to the fairlead. Once the hook is suitably attached to the vehicle, power in the remaining slack in the winch rope by "pulsing" the power in on the remote until there is minimal slack in the winch wire rope.

**SPOOLING****SPOOLING OUT**

- Freespooling is generally the quickest and easiest way to spool out wire rope. Before freespooling wire rope out from the winch, power out enough rope to remove any tension the wire rope may be under. Disengage the clutch. Now freespool by manually spooling out enough wire rope for the winching operation. Always leave at least 5 wraps on the drum.

**SPOOLING IN UNDER LOAD**

- Never exceed winch's rated line pull.
- Power in the wire rope evenly and tightly on the drum. This prevents the outer wire wraps from drawing into the inner wraps, binding, and damaging the wire rope.
- Avoid shock loads when spooling, by using the control switch intermittently to take up wire rope slack. Shock loads can momentarily far exceed the winch and wire rope ratings.

**SPOOLING IN UNDER NO LOAD**

- **Assisted** - Have your assistant hold the hook with the hook strap putting as much constant tension on the wire rope as possible. While keeping tension, the assistant should walk toward the winch while you operate the control switch spooling in the wire rope. **Release the switch when the hook is a minimum of 8 ft [ 2.44 m ] from the fairlead opening.** Spool in the remainder for storage.
- **Unassisted** - Arrange the wire rope to be spooled so it will not kink or tangle when spooled. Be sure any wire rope on the drum is tightly and evenly layered. Spool enough wire rope to complete the next full layer on the drum. **Tighten and straighten the layer. Repeat process until the hook is a minimum of 8 ft [ 2.44 m ] from the fairlead opening.** Spool in the remainder for storage.

**SPOOLING REMAINDER FOR STORAGE**

- Secure the hook to a suitable anchor point near the winch. Carefully power in the remaining wire rope, joggling the control switch to take up the last of the slack. Be careful not to over tighten or damage may occur to the wire rope or anchor point.

**COOLING FAN**

The cooling fan is used to cool the winch motor. A thermostat inside the winch motor automatically controls the fan and turns it on and off according to the winch motor temperature. The fan will not run until the winch motor reaches a predetermined temperature.

There is also a fan override switch in the remote handle that can be used to operate the fan. When properly connected the fan delivers cooling air that flows through the inlet hose to the winch motor. Hot air from the winch motor is exhausted through the outlet hose.

See the Cooling Fan Mounting Instructions for proper fan, hose, and control cable installation.



**OVERLOADING/OVERHEATING**

This winch is rated for intermittent duty. When the motor approaches stall speed, very rapid heat buildup occurs which may cause motor damage.

Double-line rigging (see Basic Guide to Winching Techniques) will reduce the amperage draw, and reduce heat buildup in the motor. This allows longer continual use.

**CLEANING**

- Do not direct high pressure water (pressure washers, car washes, etc.) directly between the drum support and drum flange or clutch lever.
- Use low pressure water and a soapy rag or sponge to clean the winch.
- Avoid using chemicals that may damage the finish.
- Thoroughly clean salt residue from the winch as soon as possible to minimize corrosion.

**BATTERY RECOMMENDATIONS**

A fully charged battery and good connections are essential to the proper operation of your winch. The minimum requirement for a 12 volt DC battery is 650 Cold Cranking Amperes.

**MAINTENANCE**

- No lubrication is required for the life of the winch, unless the winch is submerged in water. If this occurs, a qualified service center must complete service as soon as possible to prevent corrosion damage. If the control pack is submerged, it must be replaced when the winch is serviced.
- Check battery cables and electrical connections at 90 day intervals to be certain they are clean and tight at all connection points.
- Inspect the wire rope before and after each winching operation. When damaged, replace with the size specified in the Replacement Parts List.
- The wire rope must always spool onto the drum as indicated by the drum rotation decal on the winch.

**WINCHING**

 **CAUTION**



To avoid minor or moderate injury:

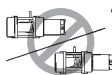

- Always wear heavy leather gloves when handling a wire rope.
- Never winch with less than 5 wraps of wire rope around the drum, the wire rope could come loose from the drum.

**OPERATOR'S SAFE WORKING STATIONS**

The operator should always operate the winch in a safe position while pulling a load. The safe areas are perpendicular to the wire rope or in the vehicle with the hood up (if winch is mounted on front of vehicle). This will help prevent the wire rope from striking the operator if it fails under load. Operate the winch, when possible, at the end of the remote control length. The operator must be at least 8 ft (2.44m) from the winch while operating. This will prevent entanglement with the fairlead and keep the operator out of harms way during winch load pulling. **Never work around wire rope while under load.**

**SOUND EMISSIONS**

The winch is designed so that the sound emissions do not exceed 70 dBA from the operator's station. The operator must be at least 8 ft. (2.44m) from the winch while operating. If the winch is exceeding 70 dBA from the operator's station, have it inspected at an authorized service center.



Les directives suivantes comprennent des indications intitulées AVERTISSEMENT, ATTENTION, AVIS et REMARQUE. Chacune a un objectif bien précis : AVERTISSEMENT présente des consignes de sécurité soulignant un danger potentiel qui, s'il n'est pas évité, peut entraîner des blessures graves ou la mort. ATTENTION comprend des consignes de sécurité signalant un danger potentiel qui, s'il n'est pas évité, peut entraîner des blessures légères ou modérées. ATTENTION sert aussi à signaler une utilisation dangereuse. ATTENTION et AVERTISSEMENT identifient un danger, indiquent comment l'éviter et montrent ses conséquences possibles si on l'ignore. AVIS présente des consignes visant à éviter les dommages matériels. REMARQUE donne des renseignements additionnels qui aident à accomplir une procédure. **TRAVAILLEZ PRUDEMMENT!**

 **AVERTISSEMENT**

**DANGER DE HAPPEMENT PAR DES PIÈCES MOBILES**

Le non-respect des consignes peut entraîner des blessures graves ou la mort.

Pour éviter de se blesser les mains ou les doigts :

- Toujours garder les mains éloignées du câble, de la boucle du crochet, du crochet et de l'ouverture du guide-câble durant l'installation et l'utilisation du treuil et l'enroulement ou le déroulement du câble.
- Toujours faire très attention durant la manipulation du crochet et du câble pendant les manœuvres de déroulement.
- Toujours utiliser le cordon du crochet fourni pour enrouler ou dérouler le câble, durant l'installation ou l'utilisation pour éviter de se blesser les mains ou les doigts.

 **AVERTISSEMENT**



**RISQUES ASSOCIÉS AUX PRODUITS CHIMIQUES ET RISQUE D'INCENDIE**

Le non-respect des consignes peut entraîner des blessures graves ou la mort.

- Toujours retirer les bijoux et porter des lunettes de sécurité.
- Ne jamais se pencher au-dessus de la batterie en procédant aux connexions.
- Avant de percer, toujours s'assurer que la zone ne contient pas de conduites de carburant, le réservoir de carburant, de conduites de frein, de câblage électrique, etc.
- Ne jamais faire passer des câbles électriques:
  - Sur des bords tranchants.
  - Par des pièces mobiles ou à proximité de celles-ci.
  - À proximité de pièces pouvant devenir chaudes.
- Toujours isoler et protéger tous les fils et bornes électriques exposés.
- Toujours installer les capuchons de borne de la manière indiquée dans les instructions d'installation.

 **AVERTISSEMENT**



**DANGER DE CHUTE OU D'ÉCRASEMENT**

Le non-respect des consignes peut entraîner des blessures graves ou la mort.

- Ne jamais utiliser comme palan aérien ou pour suspendre une charge.
- Ne jamais utiliser pour soulever ou transporter des personnes.